

HOSE ASSEMBLY

ASSEMBLY INSTRUCTIONS

USING 303 HOSE AND 491 FITTINGS

To make hose assembly of length "L", cut hose to length "J". Obtain "J" length by subtracting proper fitting allowances.

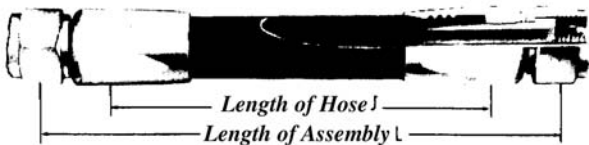

Hose & Fitting Dash No.	-3	-4	-5	-6	-8	-10	-12
Fitting Allowance* (in.)	1.30	1.30	1.48	1.54	1.88	2.00	2.00

*Allowance for 2 fittings.

step 1 Cut hose squarely to length. Use hose cut-off machine or fine tooth hacksaw. Do not remove cover.

step 2 Place socket in vise. Do not overtighten vise on thin-walled sockets of lightweight fittings. Screw hose into socket until it bottoms. Back-off 1/4 turn.

step 3 Tighten nipple and nut on assembly mandrel.

step 4 Lubricate inside of hose and nipple threads liberally. Use lubricating oil, petrolatum or light grease.

step 5 Screw nipple into socket and hose using wrench on ass'y tool hex. Nut must swivel freely when assembly tool is removed. Maximum allowable gap is 1/16 inch. L.P.S.-1 is an excellent lubricant for use in hose assembly.

CLEAN, INSPECT, PROOF TEST

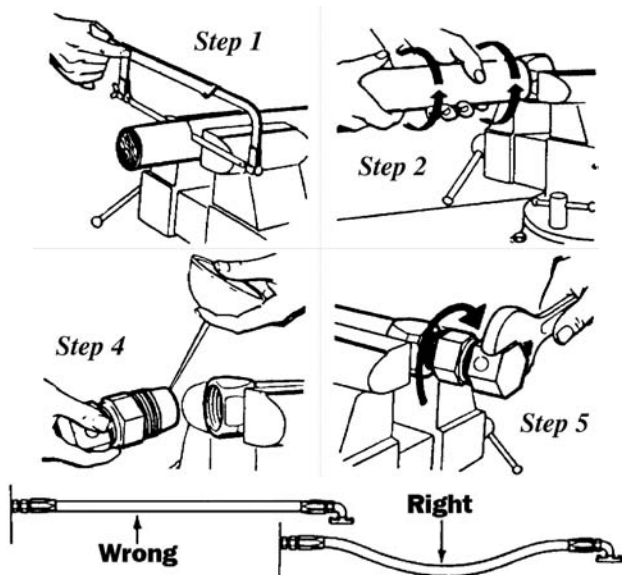

PLANNING HOSE LINE INSTALLATIONS

1. Provide slack or bend in the hose line to provide for changes in length that will occur when pressure is applied.

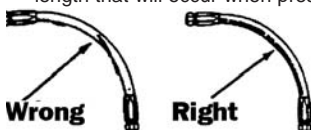

2. Observe linear stripe. Hose must not be twisted. High pressures applied to a twisted hose may cause failure or loosen the nut.



*10781-4 Clamp to be used to secure the Firesleeve material on each end over the basic hose assembly. Specify size. . . .



End Dip for Firesleeve - P/N 5027

USING 601 HOSE AND 816 FITTINGS

To make hose assembly of length "L", cut hose to length "J". Obtain "J" length by subtracting proper fitting allowances.

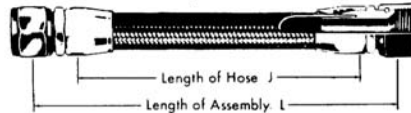

step 1 - Cut hose squarely to length. Use hose cut-off machine or fine tooth hacksaw. To minimize wire braid flare-out, wrap hose with masking tape and saw through tape. Remove tape before step 2.

step 2 - Insert hose in socket with a twisting, pushing motion until hose is in line with back of socket threads.

step 3 - Important-mark hose position around hose at rear of socket. Use a grease pencil, painted line or tape.

step 4 - Lubricate inside of hose & nipple threads liberally. Use SAE 30 lubricating oil. Avoid getting oil in the cutting spur of the nipple.

step 5 - Carefully insert nipple and engage nipple and socket threads while holding hose in position with other hand. Make sure that hose does not push out of socket by observing mark made in step 3.

step 6 - Complete assembly using wrench while continuing to hold in position. Maximum allowable gap is .041" in sizes 3, 4, & 5, and .031" in size 6 & up.

step 7 - IMPORTANT—check for hose push-out by observing hose position mark. None should be evident.

CLEAN, INSPECT, PROOF TEST

Note: Hose push out after proof test should not exceed 1/32" on sizes 12 and up. None is allowable on smaller sizes.

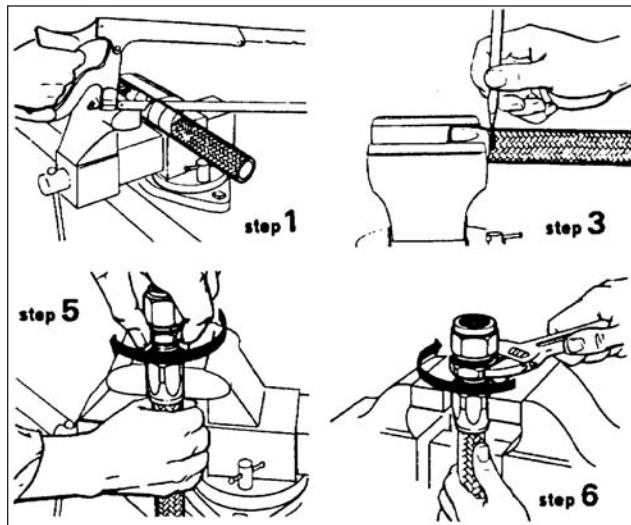

STRATOFLEX 2650 FIRESLEEVE



Part No.	Use With Hose No.				*10781-4 Clamp	Price Per Ft.
	124	193	111	156		
2650-6	-4	-	-	-	-	-
2650-8	-6	-3	-	-4	22CR	-
2650-9	-	-4	-	-5	22CR	-
2650-10	-8	-	-4	-6	22CR	-
2650-11	-	-6	-	-	-	-
2650-12	-10	-	-5,-6	-8	22CR	-
2650-13	-	-8	-8	-	-	-
2650-14	-12	-	-	-	22CR	-
2650-16	-	-10	-10	-10	32CR	-
2650-18	-	-	-	-12	32CR	-
2650-20	-16	-	-12	-	32CR	-
2650-22	-	-	-16	-16	32CR	-