

UMA 1-1/4" ENGINE INSTRUMENTS



Monitor your engine's vitals with a full line of space saving 1-1/4" engine instruments with 240 degree analog sweep. These instruments allow you the opportunity to utilize panel space without compromising readability. No longer do you have to decipher cluster gauges or push buttons for readings or try to concentrate on flashing numbers. These premiere UMA instrument are electronic and can be powered from 14 or 28 volts. Signals are acquired from remote mounted sensors, processed and displayed on analog dials with easy to read markings. Each gauge uses rugged aircore meter movement for vibration resistance and repeatability. Each gauge can be placed in a 1-1/4" diameter hole and mounted behind the panel with (4) 6-32 screws. They can be cluster mounted as close as 11/2" centers.

STREAMLINE • STACKABLE • EASY TO READ • RUGGED DESIGN

CYLINDER HEAD TEMP. (CHT)

Description	Part No.	Price
CHT Gauge 100-300°F	10-00035	.
CHT Gauge 100-600°F	10-00036	.
CHT Thermocple 14mm Plug (Rotax)	10-00962	.
CHT Thermocple 18mm Plug (Lyc.)	10-00963	.
CHT Thermocple 3/8-24 Bayonet (Lyc.)	10-00795	.

OIL PRESSURE

Description	Part No.	Price
Oil Pressure Gauge 0-80psi	10-00037	.
Oil Pressure Gauge 0-130psi	10-00038	.
Oil Pressure Sender 0-80psi	10-00007	.
Oil Pressure Sender 0-150psi	3060-18	.

FUEL QUANTITY

Description	Part No.	Price
Fuel Qty. Ind. (Float 240-30)	10-00039	.
Fuel Qty. Ind. (Cap. 5v)	10-00040	.
Sender (Float type 240-30 ohms)	10-00056	.
Sender (Capacitance 0-5V)	10-00797	.

AMMETER

Description	Part No.	Price
Ammeter ±30 Shunt incl.	10-00041	.
Ammeter ±100 Shunt incl.	10-00043	.
Ammeter +30	10-02380	.
Ammeter +60	10-02381	.
Ammeter +80	10-02382	.
Ammeter +100	10-02383	.

WATER PRESSURE

Description	Part No.	Price
Water Press. Gauge 0-15psi	10-00044	.
Water Press. Gauge 0-30psi	10-00045	.

WATER TEMPERATURE

Description	Part No.	Price
Water Temp. Gauge 100-300°F	10-02457	.

OUTSIDE AIR TEMPERATURE

Description	Part No.	Price
OAT (-25) -40°C	10-02385	.
OAT (-10) -110°F	10-02386	.

EXHAUST GAS TEMPERATURE (EGT)

Description	Part No.	Price
EGT Gauge 700-1700°F	10-00046	.
EGT Thermocple Clamp style (Lyc.)	10-00828	.
EGT Thermocple 8mm, Bayonet (Rotax)	10-00967	.

FUEL FLOW

Description	Part No.	Price
Fuel Flow 0-8 6PH	10-02403	.
Fuel Flow 0-20 6PH	10-02402	.
Fuel Flow 0-30 6PH	10-02405	.

OIL TEMPERATURE

Description	Part No.	Price
Oil Temp. Gauge 100-300°F	10-00047	.
1-1/4 inch VDO - TSO'd Electronic Temperature Gauges 100-300 deg.F	10-02779	.
Oil Temp. Probe 3/8-24 (Automotive)	10-00828	.
Oil Temp. Probe 5/8-18 (Lyc./Cont.)	10-00418	.
Oil Temp. Probe 10mm (Rotax 912/914)	10-00973	.

FUEL PRESSURE

Description	Part No.	Price
Fuel Pressure Gauge 15psi	10-00048	.
Fuel Pressure Gauge 30psi	10-00049	.
Fuel Pressure Gauge 0-80 psi	10-00050	.
Fuel Pressure Sender 80psi	10-00007	.

VOLTMETER

Description	Part No.	Price
Voltmeter 18-36V	10-00052	.
Voltmeter 9-17V	10-00578	.

FLAP INDICATOR

Description	Part No.	Price
Flap Position Indicator 0-30°	10-00053	.
Flap Position Indicator 0-40°	10-00054	.
Flap Position Indicator up-full	10-00055	.
Flap Indicator Transducer	AN5785	.

MANIFOLD PRESSURE

Description	Part No.	Price
5-35"	10-02438	.
5-50"	10-02439	.

For Experimental aircraft only. See next page for TSO'd Gauges. Mount individually or as a cluster.

MOUNTING INFORMATION

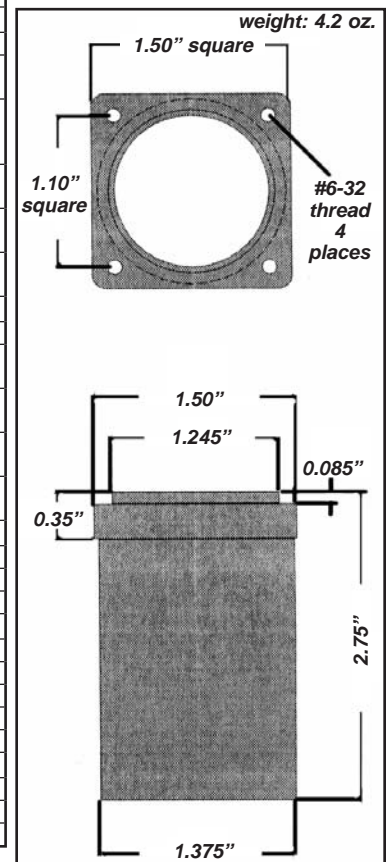

IN